

STAMP MANUFACTURER'S ID "R",
PROPERTY CLASS SYMBOL "10",
PILOT LENGTH "1.5" AND
"STRUX®" ON TOP OF NUT,
90° APART, AS SHOWN.

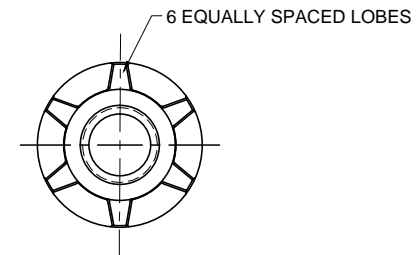

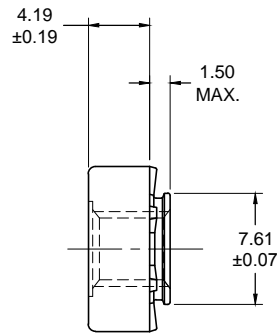
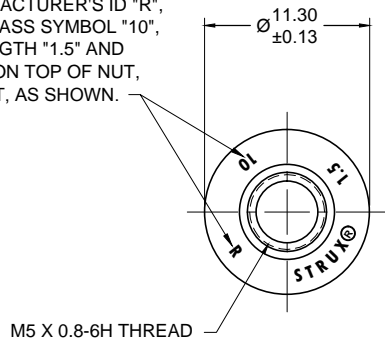

STRUX® Registered Clinch Nut

NOTES:

1. MATERIAL: ISO 898-2 (10)
2. RECOMMENDED PANEL HOLE SIZE: 7.68 - 7.78 mm.
3. PANEL THICKNESS: 1.5 mm. MIN.
4. UNDERHEAD DETAIL CONTROLLED BY MANUFACTURER TO MEET PERFORMANCE REQUIREMENTS.

ALL DIMENSIONS ARE IN MM

THIS DRAWING IS THE PROPERTY OF RAMCO SPECIALTIES, INC.. IT SHALL NOT BE REPRODUCED, COPIED or EXPOSED IN WHOLE or IN PART AS THE BASIS FOR MANUFACTURING or SALE OF THE ITEM(S) DISCLOSED ON THIS DRAWING;

LET	DATE	REVISION	BY
 RAMCO ™ SPECIALTIES, INC. HUDSON, OHIO, U.S.A.			
M5 X 0.8 STRUX® CLINCH NUT, 1.5 PILOT			
THIRD ANGLE PROJECTION			
DATE	SCALE	DRAWING NO.	
09-23-2015	2 : 1		
DRAWN	APP.	STN0515	
JD	MB		