

STAMP MANUFACTURER'S ID "R",  
PROPERTY CLASS SYMBOL "10",  
PILOT LENGTH "2.3" AND  
"STRUX®" ON TOP OF NUT,  
90° APART, AS SHOWN.

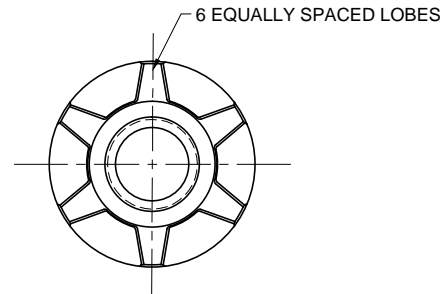
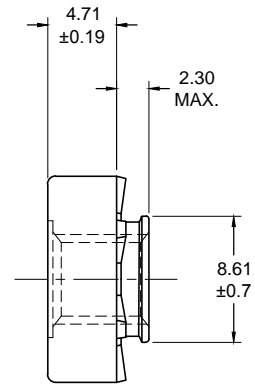
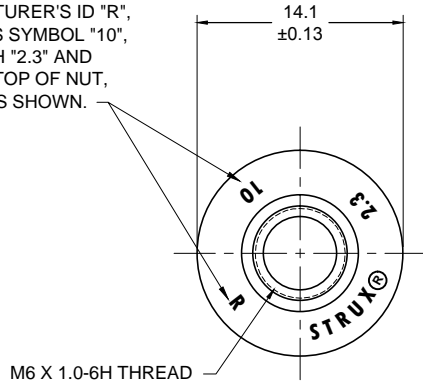

## STRUX® Registered Clinch Nut

### NOTES:

1. MATERIAL: ISO 898-2 (10)
2. RECOMMENDED PANEL HOLE SIZE: 8.68 - 8.78 mm.
3. PANEL THICKNESS: 2.3 mm. MIN.
4. UNDERHEAD DETAIL CONTROLLED BY MANUFACTURER TO MEET PERFORMANCE REQUIREMENTS.

ALL DIMENSIONS ARE IN MM

THIS DRAWING IS THE PROPERTY OF RAMCO SPECIALTIES, INC.. IT SHALL NOT BE REPRODUCED, COPIED or EXPOSED IN WHOLE or IN PART AS THE BASIS FOR MANUFACTURING or SALE OF THE ITEM(S) DISCLOSED ON THIS DRAWING;

LET	DATE	REVISION	BY

 **RAMCO**™  
SPECIALTIES, INC.  
HUDSON, OHIO, U.S.A.

M6 X 1.0 STRUX® CLINCH NUT, 2.3 PILOT

THIRD ANGLE  
PROJECTION 

DATE  
09-23-2015

SCALE  
2 : 1

DRAWING NO.

DRAWN  
JD

APP.  
MB

STN0623