

MANUFACTURER'S IDENTIFICATION "R" AND PROPERTY CLASS SYMBOL "10" LOCATED ON TOP OF NUT, 180° APART, AS SHOWN.

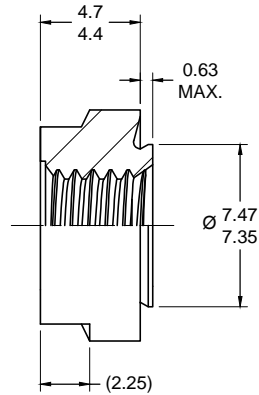

SECTION A-A  
SCALE 3:1

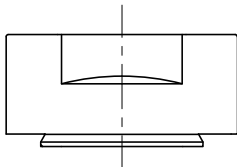
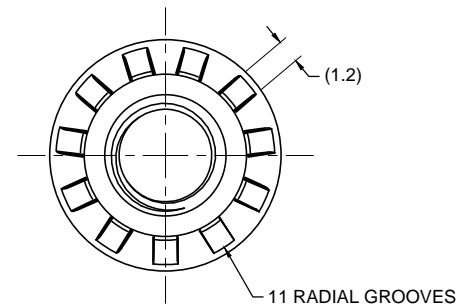

**RAMTEK™ PROPRIETARY PRODUCT  
PATENT PENDING**

**W721635**

1. MATERIAL: ISO 898-2 (10)
2. HARDNESS: HRc 35 - 39
3. PROOF LOAD: 14.8 kN
4. FINISH: PLAIN
5. PANEL THICKNESS: 0.65 MIN.
6. IF USED IN PRE-PIERCED HOLE, RECOMMENDED HOLE SIZE IS Ø7.47 - 7.57
7. UNDERHEAD DETAIL CONTROLLED BY MANUFACTURER TO MEET PERFORMANCE REQUIREMENTS.

LET	DATE	REVISION	BY
 HUDSON, OHIO, U.S.A.			
<b>M5 PC 10 PIERCE NUT</b>			
THIRD ANGLE PROJECTION		RAMCO PART NO.	
DATE 08 - 08 - 19	SCALE 3 : 1	DRAWING NO.	
DRAWN JD	APP SA	<b>EXP-003129-C</b>	

THIS DRAWING IS THE PROPERTY OF RAMCO SPECIALTIES, INC.. IT SHALL NOT BE REPRODUCED, COPIED or EXPOSED IN WHOLE or IN PART AS THE BASIS FOR MANUFACTURING or SALE OF THE ITEM(S) DISCLOSED ON THIS DRAWING;